

# HGN

series



## UL NRS Gate Valve – Flange Ends

- Size: 2.5"(DN65) to 12"(DN300)
- Working Pressure: 300 PSI
- Test Pressure: 600 PSI
- Working Temp.: 0°C to 80°C (32°F to 176°F)
- Valve Standard: UL262,ULC/ORD C262-92
- Connection Standard:  
ASME/ANSI B16.1 Class 125 or  
ASME/ANSI B16.42 Class 150 or  
BS EN1092-2 PN16 or GB/T9113.1
- Face to Face Standard: ASME B16.10
- Test Standard: UL262,ULC/ORD C262-92



**HGN-300FF**

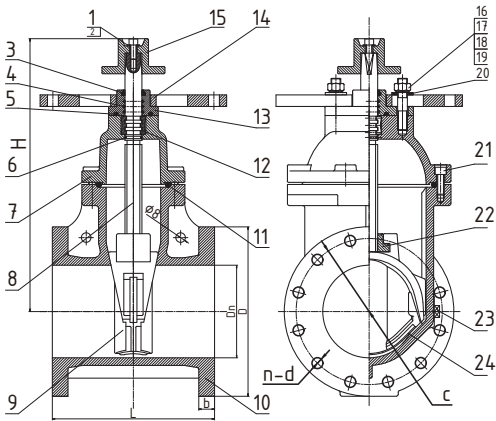

ITEM	PARTS	MATERIAL
1	FLAT WASHER	S. S. 304
2	INNER HEXAGON SCREW	S. S. 304
3	SEALING GLAND	EPDM
4	O-RING	EPDM
5	SEALING RING	EPDM
6	O-RING	EPDM
7	BONNET	DI
8	STEM	S. S. 304
9	DISC	EPDM+DI
10	BODY	DI
11	SEALING RING	EPDM
12	RETAINING RING	C954
13	GLAND	DI
14	TERMINAL PAD	DI
15	LINK BLOCK	DI
16	NUT	S. S. 304
17	STUDS	S. S. 304
18	SPRING WASHER	STEEL
19	WASHER	STEEL
20	WASHER	STEEL
21	INNER HEXAGON SCREW	STEEL
22	MASTERSCREW	C954
23	PLUG	C28000
24	SKELETON	DI

SIZES		DIMENSIONS (MM)					
Inch	mm	L	D	b	c	n-d	H
2.5"	DN 65	190	178	17.5	139.5	4-φ19	292
3"	DN 80	203	191	21	152.5	4-φ19	322
4"	DN 100	229	229	24	190.5	8-φ19	342
5"	DN 125	254	254	23.9	216	8-φ22	412
6"	DN 150	267	279	25.4	241.5	8-φ22	448
8"	DN 200	292	343	28.6	298.5	8-φ22	534
10"	DN 250	330	406	30.2	362	12-φ25	635
12"	DN 300	356	483	31.8	432	12-φ25	720